

Table of Contents

Introduction	1
Description	1
<i>Controls and Indicators</i>	1
Overview of Unit Function	3
<i>Standard Mode</i>	3
<i>Manual Mode</i>	3
<i>Continuous Mode</i>	3
PRG Option	3
Model/Serial Number	4
The Utility Program	4
The Scanning Program	5
Calibration	5
<i>Setup</i>	5-9
<i>Special Considerations – RS-485 CAM-to-RS-232 Port</i>	9
Bench Check	9
<i>Terminal Emulation in DOS</i>	9
<i>Terminal Emulation in Utility</i>	11
<i>Commands</i>	11
<i>User Input Scaling</i>	11
<i>Trimming the Output of Voltage CAM's</i>	11
<i>Trimming the Output of Current CAM's</i>	12
Verifying CAM Basic Function	13
<i>Ramping Rate & Host Control Check</i>	13
<i>Ramping Rate & Manual Mode Check</i>	13
<i>Override of Host Control</i>	14
<i>Acknowledge/Checksum Check</i>	14
CAM Configuration – Running the Utility Program	15
<i>Required Device Drivers</i>	15
<i>Loading Utility</i>	15
<i>Utility Utilities</i>	16
<i>Context-Sensitive HELP</i>	16
Installation	19
Mounting	19
Electrical Connections & Communications Wiring	22
<i>RS-232C Considerations</i>	22
<i>RS-485 Considerations</i>	22
Continuous Mode Considerations	25
<i>Enable/Disable</i>	27
Power Supply Considerations	27
Operation	27
Executing Commands Directly — Terminal Emulation	30
Running the Scan Program — Scan.bat	31
Continuous Mode	31
Manual/Local Mode	32
<i>Up/Down Local/Manual Control</i>	32
<i>Controller Input Local/Manual Control</i>	32
<i>High/Low Limiting Local/Manual Control</i>	33
Third Party Software	33
Maintenance	33
Troubleshooting	33
Appendix – Index of Figures and Tables	A1

Introduction

Moore Industries' Computer-to-Analog Module (CAM) is a microprocessor-based interfacing unit used to link digital controllers and analog devices.

This manual provides information needed to calibrate, install, operate, maintain, and troubleshoot the CAM. Additionally, it includes a brief description of the unit's physical characteristics and features, a summary of operational and performance specifications, and an overview of Moore Industries' product data tracking system.

An appendix provides a convenient index of figures and tables used in the manual.

Moore Industries' CAM/DCM/SCM Command Reference Guide is offered as a companion to this publication. That manual is intended to provide more detailed information on CAM commands for configuration and operation, as well as commands for its sister unit, Moore Industries' Sensor-to-Computer Module (SCM), and Discrete Concentrator Module (DCM).

A copy of the Command Reference Guide is typically included with each CAM shipment. Additional copies are available from the factory, or through your Moore Industries Sales Representative.

User's Manual Conventions. "Notes" are used in this manual to call attention to practices that, unless avoided, could present inconveniences to the user.

The symbol "Ø" is used to distinguish the numeral zero from upper case, or capital "O" where necessary.

The symbol "↵" is used to represent ENTER (HEX 0D) in this manual. ENTER (RETURN on some keyboards) is required to terminate all CAM commands.

The symbol "*" is used to represent an asterisk, which is the CAM response indicator.

The term "host" refers to any digital device that is capable of asynchronous ASCII string output at standard RS-232C or RS-485 logic levels (the CAM is configured at the factory for either RS-232C or RS-485 input, according to customer requirement).

A device such as a personal computer (PC), programmable logic controller (PLC), "dumb" terminal, or Moore Industries' SCM configured for Continuous Mode, for example, may be used as a host.

Description

The CAM is a self-contained digital-to-analog converter. It is configured according to customer specification to accept ASCII commands and provide ASCII responses via an RS-232C or RS-485 communications interface, and to provide user-variable levels of either current or voltage output based on those commands.

The CAM is available in either the hockey-puck (HP) or plastic DIN-style housing.

The HP-style CAM is equipped with spring clips, most often used with Moore Industries' 2- or 3-hub, high-cover, solid-top, explosionproof enclosure. The spring clips provide for CAM installation in the enclosures without the use of additional fasteners, drilling, or tapping. The enclosures are available with hardware for surface or pipe mounting.

Plastic, DIN-style units snap on to standard, 35 mm, DIN Top-hat rails (DIN EN50022), or can be ordered with an optional adapter for use with 32 mm, G-type rails (DIN EN50035).

The terminal blocks on both the HP- and DIN-style CAM are located on the unit front panel. Each terminal is clearly labeled. Refer to the Calibration Setup Section of this manual for terminal labeling breakouts.

Controls and Indicators. Except when in its Manual Mode or when responding to the expiration of the Watchdog Timer setting (both described later), the operation of the CAM is entirely controlled by commands issued by the connected host. There are no external controls or indicators.

Table 1 provides a summary of operational and performance specifications of Moore Industries' CAM.

Table 1. CAM Operational and Performance Specifications

Characteristic	Specifications
Input	<p>Digital ASCII Strings (commands) in a simple, Command/Response Protocol. Tables in Operation Section of this manual comprise a CAM command summary. Refer also to SCM/CAM Command Reference Guide.</p> <p>Discrete. Three terminals configured with internal pull-up resistors for direct input/control based on truth table in EEPROM. Self-wiping switches designed for low current operation are recommended.</p>
Output	<p>Customer-specified at time of order.</p> <p>Voltage: 0 to 1 V -1 to 1 V 0 to 5 V -5 to 5 V 0 to 10 V -10 to 10 V</p> <p>Current: 0 to 20 mA (Standard command set provides for user adjustments for 4 to 20 mA range).</p>
Power	<p>12 to 30 Vdc. Unregulated. All units reverse-polarity protected. Ripple must be limited to 5 V peak-to-peak.</p>
Controls	<p>All unit setup and operational information processed by internal, microprocessor-based circuitry. Settings stored in internal EEPROM.</p>
Communications	<p>RS-232C or RS-485 customer-specified at time of order.</p> <p>Range: 10,000 feet, maximum when hard wired. Unit is compatible with repeaters and modems for virtually unlimited range capability with radio or telephone modems (see NOTE 1).</p> <p>Number of Units: Up to 124 CAM's can be connected to a single COM port. A repeater is required for every 32 CAM's. (see NOTE 1).</p> <p>Format: Standard NRZ asynchronous serial communications. Each character consists of 1 start bit, 7 data bits, one parity bit, and one stop bit.</p> <p>Baud Rate: Standard command set provides for user-selectable baud rates of 300, 600, 1200, 2400, 4800, 9600, 19200, and 38400.</p> <p>Parity: User-selectable. Odd, Even, None.</p>
Performance	<p>Digital-to-Analog Computation Rate: 1000 conversions per second.</p> <p>Output Accuracy: $\pm 0.1\%$ of full-scale in all specified ranges.</p> <p>Analog Readback Accuracy: 1% of rated full-scale (available with PRG option only).</p> <p>Output Resolution: 12 bit.</p> <p>Isolation: Output to 500 Vrms, maximum.</p> <p>Analog Output Protection: Current-configured units to 240 VAC. Voltage-configured units to ± 30 VAC.</p> <p>Load Capability: Current-configured units to 600Ω maximum. Voltage-configured units to 10 mA maximum, 5 mA minimum.</p> <p>Power Consumption: 1 W maximum per connected CAM for voltage-configured units. 1.3 W maximum in current-configured units, current draw inversely proportional to line voltage.</p> <p>Current Output Voltage Compliance: 12 V.</p>
<p>Table continued on next page.</p>	

Table 1. CAM Operational and Performance Specifications (continued)

Characteristic	Specifications
Performance (continued)	<p>Output Ramping Rate: Factory-set. 5 seconds from zero to full-scale, auto or manual. PRG-equipped units provide adjustable ramping rates from 0.01 mA or V/sec to 10,000 mA or V/sec (rates accurate $\pm 10\%$).</p> <p>Settling: 300 μsec to 0.1% of rated full-scale, typical; 1.0 msec, maximum.</p> <p>Discrete Input Maximum: ± 30 Vdc.</p> <p>Discrete Input Switching Levels: 3.5 V minimum for high, 1.0 V maximum for low.</p> <p>Ambient Temperature Effect: $\pm 0.005\%$ of rated span per $^{\circ}\text{C}$ change ($\pm 0.0014\%/^{\circ}\text{F}$) throughout rated operating temperature range.</p> <p>Accuracy of Analog Readback as Affected by Ambient Temperature: 2% of rated full-scale, maximum, within the rated operating range (available in PRG-equipped CAM's only).</p> <p>Zero Drift: ± 1 μA per $^{\circ}\text{C}$ change (± 0.11 $\mu\text{A}/^{\circ}\text{F}$) for current-configured units. ± 30 μV per $^{\circ}\text{C}$ change (± 17 $\mu\text{V}/^{\circ}\text{F}$) for voltage-configured units.</p>
Environmental Ratings	<p>Ambient Temperature Operating Range: -25 to 70 $^{\circ}\text{C}$ (-13 to 158 $^{\circ}\text{F}$).</p> <p>Ambient Temperature Storage Range: -25 to 85 $^{\circ}\text{C}$ (-13 to 185 $^{\circ}\text{F}$).</p> <p>Ambient Humidity Operating Range: 0 to 95%, non-condensing.</p>
<p>NOTES:</p> <ol style="list-style-type: none"> 1. Range dependent upon ambient noise, selected communications standard (RS-232C or RS-485), baud rate, and number of CAM's installed. Refer to Installation Section of this manual for specific recommendations. Consult factory for details on compatible repeaters and modems. 2. Refer to Installation Section of this manual for CAM outline dimensions. 	

Overview of Unit Function

There are three operating modes available in the CAM: Standard, Manual, and Continuous.

Standard Mode. In this mode, the CAM provides either current or voltage output. Each unit is configured at the factory according to customer specifications at time of order. The level of CAM output in Standard Mode is controlled by user-issued ASCII command strings transmitted from a host device.

Manual Mode. This mode overrides the commands from the host. The unit's internal logic circuitry (truth table) is used to sense the state of user-supplied switches or other discrete output devices (CMOS, TTL), and this data is used to ramp the analog output up or down at an interruptible, predetermined rate.

Continuous Mode. In this mode the CAM is equipped with the User Programmability (PRG) Option, which allows it to accept commands from a Continuous Mode SCM (SCM equipped with the C Option), or a Discrete Concentrator Module (DCM). PRG-equipped CAM's can be used to scale or convert sensor data (from these type of device), or to work in combination with SCM's, DCM's, and actuators in devising a simple, "hostless" DAC system.

PRG Option

In addition to Continuous Mode capability, CAM's equipped with the PRG Option provide the user with an added dimension of control over unit function. Rates for output ramping (manual or host-controlled slope), sensor-to-output scaling and conversion, true output readback, settings for non-volatile memory-resident fail-safe/startup values, and a Watchdog Timer are all user-controllable aspects of the PRG CAM's operation.

The Scanning Program

Also menu-driven, the Scanning program is intended to function as an alternative to operating the CAM using commands directly from the host, or if compatible third-party DAC packages are not available. It is also provided on the distribution diskettes included with all CAM shipments.

Refer to the Operation Section of this manual for instructions on its installation.

NOTES

As with the Utility program, the Scanning program is NOT required when operating the CAM. The unit also recognizes "straight ASCII" commands directly.

Moore Industries also provides software drivers that facilitate the use of CAM and PRG CAM with several popular third-party DAC packages.

Refer to the CAM/DCM/SCM Command Reference Guide for information on setting up and operating the CAM directly with commands.

Calibration

Before shipment, every CAM is manufactured according to, and tested for, compliance with Moore Industries' strict quality standards. Each unit is guaranteed to perform according to specification.

A bench check of the unit is recommended before installation, however, in order to discover any damage that may have occurred during shipment.

Such a check also affords the user the opportunity to become familiar with the basics of CAM hookup, output trimming, setup, and operation in a comparatively "safe" environment, i.e. isolated from the unit's eventual application.

In this manual, CAM calibration consists of both a bench check of the unit's basic operations, and the procedures for the initial configuring of CAM operating parameters.

Setup. Table 2 lists the equipment required to perform all of the procedures described as part of CAM calibration. The equipment is not supplied with the unit, but should be readily available in most testing areas.

Table 3 summarizes the abbreviations used in the terminal labeling of the CAM.

Figures 1, 2, and 3 show the standard hookups for calibrating the various types of CAM. These setups are also useful for CAM configuration (Utility or SU command). Each includes illustration of the connection of the external switches which can be used to check the unit's Manual Mode.

NOTE

The connectors shown in the figures are for reference purposes only. Always refer to the manufacturer's pin-out specifications for the board, modem, or cabling connectors being used when connecting the CAM to calibration equipment.

Refer to the model number of the CAM being checked to determine which figure shows the appropriate setup. Connect the CAM to the equipment listed in table 2 as illustrated. Apply appropriate power and turn on the host. Set the host to its "dumb terminal" emulation or communications mode.

NOTE

Figures 4 and 5, which show the RS-485 CAM to RS-232C port quick hookup are for use in calibration only. They are not recommended for use in the actual CAM application.

Table 2. CAM Calibration Equipment

Equipment	Specifications
<p>Host</p>	<p>Any device capable of ASCII string output communicated at RS-232C or RS-485 logic levels (as appropriate) via a standard communications port.</p> <p>Requirements:</p> <ul style="list-style-type: none"> • IBM PC XT, AT, PS2, compatible "clone", or compatible "dumb terminal" • DOS or MS-DOS version 2.0 or higher • Minimum of 384K RAM required (terminal, PC, or clone) • Monochrome, text-capable monitor • One asynchronous (serial) communications port (25- or 9-pin) designated COM1: or COM2: • One floppy disk drive, 360 or 720K, 3.5 or 5.25 inch. Disk size customer-specified (Required for use of Moore Industries' Utility or Scanning software) <p>Optional:</p> <ul style="list-style-type: none"> • Microsoft, or compatible mouse • Color monitor
<p>Device Driver</p>	<p>Required for some versions of UTILITY.BAT or SCAN.BAT when using a Host under DOS version 4.0 or later. Host, described above, must incorporate a CONFIG.SYS file in its boot routine, and it must contain DOS's ANSI.SYS device driver with the /K switch included. Refer to the documentation on the version of DOS used for instruction in installing CONFIG.SYS, DEVICE=ANSI.SYS /K, and rebooting. (See NOTE, below.)</p>
<p>Interface Cable</p>	<p>Standard PC communications cabling with one end terminating in a 9- or 25-pin connector that is compatible with the COM port of the host. The other end should have wires for pins 2, 3, and 5 (9-pin connection); or 1, 2, 3, and 7 (25-pin connection) stripped of insulation.</p>
<p>Power Source</p>	<p>Calibrated. Rated for dc output between 12 and 30 Vdc (24 Vdc, nominal).</p>
<p>Screwdriver</p>	<p>Slotted-tip. Head width 2.54 mm (0.1 in), maximum.</p>
<p>Voltmeter</p>	<p>Calibrated. Accuracy of 0.01% of span, minimum. 5 1/2-digit display Keithly Model 197, or equivalent. (Fluke Model 8800 or equivalent multimeter may also be used).</p>
<p>Switches</p>	<p>Three, self-wiping toggle- or pushbutton-type.</p>
<p>Timer</p>	<p>Stopwatch or equivalent device capable of measurement accurate to the nearest second.</p>
<p>Load Resistor</p>	<p>250Ω, ±0.01%. Precision resistor required for calibrating CAM's configured for current output to provide 1-5 V proportional output reading on voltmeter.</p>
<p>Pull-up Resistor (optional)</p>	<p>CAM discrete inputs incorporate internal pull-up resistors, but provide only 0.5 mA. Where self-wiping switches cannot be used, it may be necessary to provide extra pull-up current with a secondary, external 10 kΩ resistor. When used, this resistor should be added between the switch and the source of positive voltage.</p>
<p>NOTE: Consult your Moore Industries Sales Representative for more information on running UTILITY.BAT and SCAN.BAT under MS-Windows and later versions of DOS.</p>	

Table 3. CAM Terminal Labeling

Terminal	Abbreviation	Type of CAM	Used For
1	+OUT	All	Positive Analog Output
2	-OUT	All	Negative Analog Output
3	DI2	All	Auxiliary Discrete Input/Continuous Mode Enable
4	DI1/UP DI1/UP•	RS-232C RS-485	Discrete Input/Manual Control (See NOTES 1 & 2)
5	DIØ/DN DIØ/DN•	RS-232C RS-485	Discrete Input/Manual Control (See NOTES 1 & 2)
6	DEFAULT DEFAULT•	RS-232C RS-485	See NOTES 2 & 3
7	XMT (Y)DATA	RS-232C RS-485	Transmit Data/Data connection (See NOTE 4)
8	RCV (G)DATA•	RS-232C RS-485	Receive Commands/Data connection (See NOTES 2 & 4)
9	+VS (R)+VS	RS-232C RS-485	Positive Voltage Source Input.(See NOTE 4)
10	GND (B)GND	RS-232C Units RS-485	Ground.

- NOTES:**
1. When connected in series with simple switch and GND terminal, provides "local" control of unit's output ramping (start/stop/limit).
 2. Terminal logic is "negative true".
 3. Not for use during normal operation. Connect to GND terminal to override unit EEPROM settings for 300 baud, no parity, no echo, and universal address.
 4. Labeling includes reference to typical color coding of standard telephone cabling; (Y)=yellow, (G)=green, (R)=red, and (B)=black.

CAM

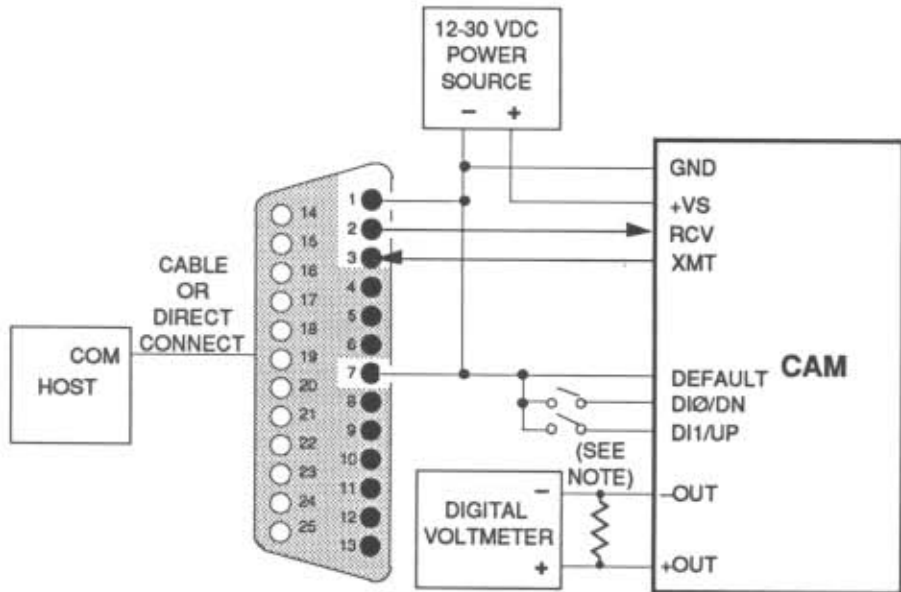

NOTE: Resistor used only when calibrating CAM's configured for current output.

Figure 1. RS-232C Calibration Hookup, 25-Pin Connector

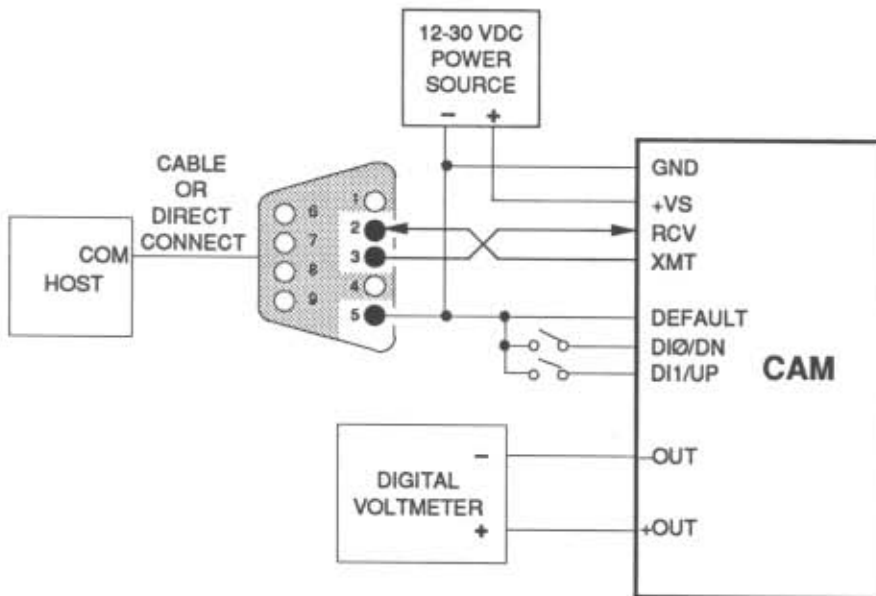

NOTE: Resistor used only when calibrating CAM's configured for current output.

Figure 2. RS-232C Calibration Hookup, 9-Pin Connector

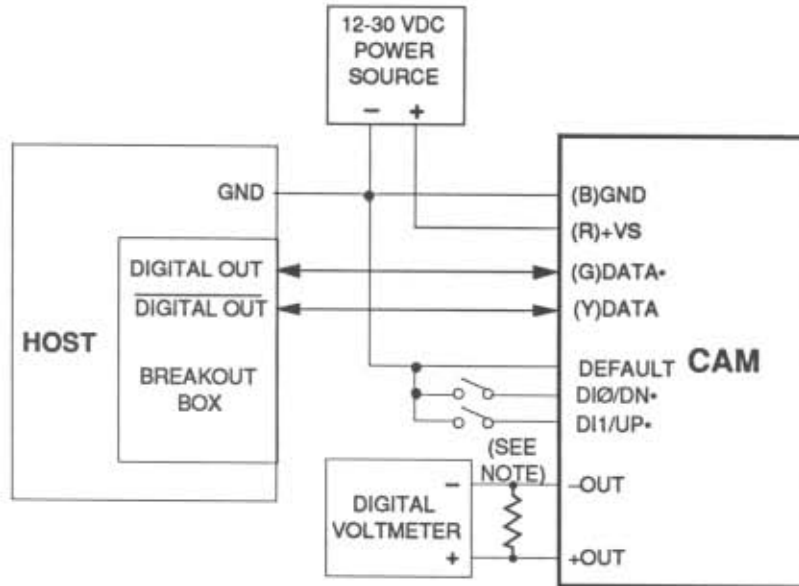

NOTE: A 250Ω resistor will produce proportional readings of 0-5V for a 0-20mA output.

Figure 3. RS-485 Calibration Hookup, Non-PC Host

Special Considerations – RS-485 CAM to RS-232C port Quick Hookup:

- Limit the RS-232C transmit current to 50 mA (all terminals that use 1488- or 1489-style interfacing schemes satisfy this requirement).

NOTE

If current limiting capability of the RS-232C output is uncertain, incorporate a resistor, 1Ω-100 kΩ, in series between the host output and the CAM input.

- Turn off the local echo of the terminal used.
- Configure the RS-232C receive threshold to function at greater than 0 V (all terminals that use 1488- or 1489-style interfacing schemes satisfy this requirement).

Bench Check

The bench check of CAM basic operation consists of trimming unit zero and full-scale output, and verifying proper output ramping rates, Manual and Host Control Override features, and command acknowledgement and checksumming.

Terminal Emulation in DOS. The commands used to effect the bench check must be transmitted from a suitable host device, described in the Manual Conventions Section earlier in this manual. The Utility program diskette shipped with each CAM order contains a simple executable program, written in Turbo Pascal (source code included) that will configure any PC or clone to operate as a dumb terminal. It sets communications parameters of 300 baud, no parity, no echo, and activates the COM1: port.

CAM

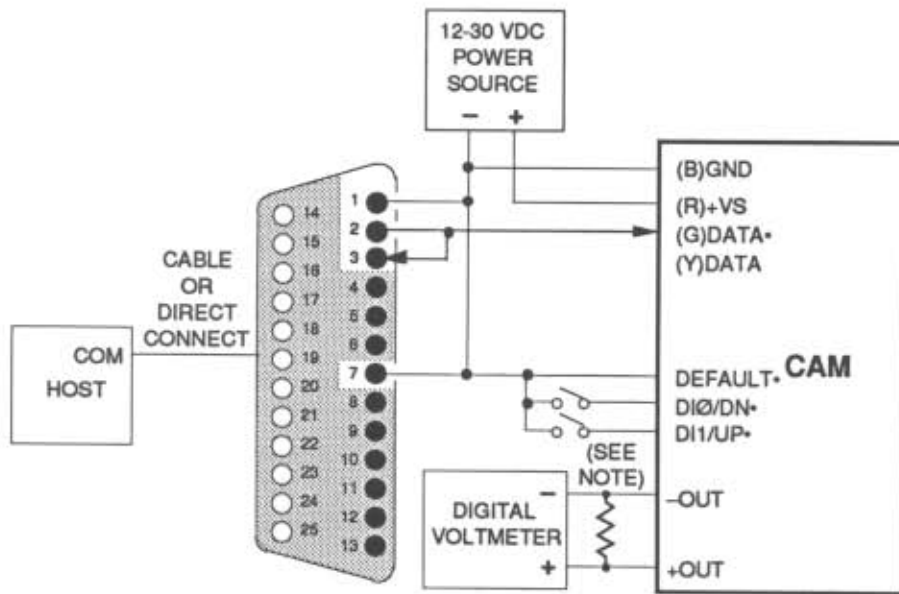

NOTE: A 250Ω resistor will produce proportional readings of 0-5V for a 0-20mA output.

Figure 4. RS-485 Calibration Hookup, RS-232C Port w/25-Pin Connector

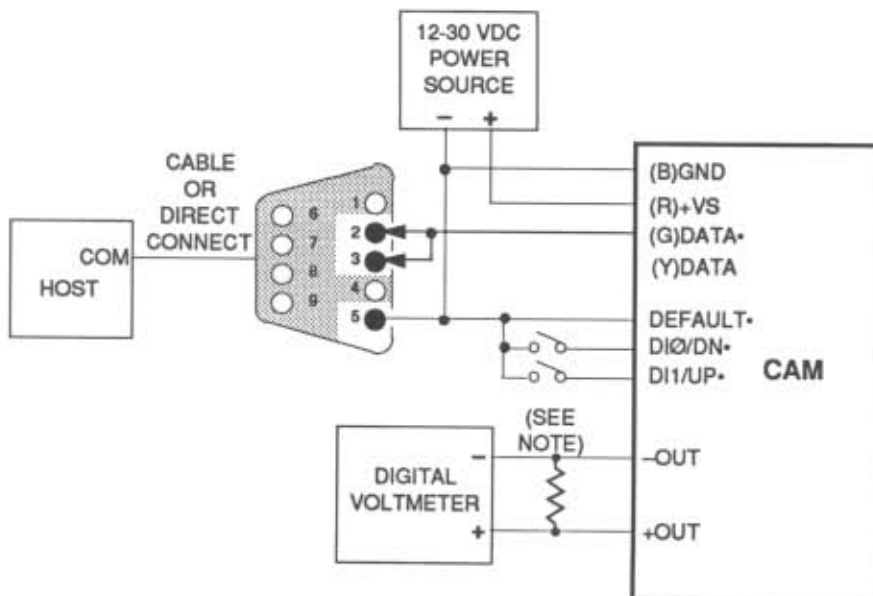

NOTE: A 250Ω resistor will produce proportional readings of 0-5V for a 0-20mA output.

Figure 5. RS-485 Calibration Hookup, RS-232C Port w/9-Pin Connector

To run this terminal emulation, insert the Utility distribution diskette into the floppy drive, and type:

[drive designator]:TERMINAL.EXE↵

"drive designator" is the drive and path where the Terminal program resides.

NOTE

Use of Moore Industries' terminal emulation program is not required to calibrate the CAM. Any program in which the host provides asynchronous ASCII output at 300 baud, with no parity, and no echo will suffice.

Terminal Emulation in Utility. A terminal emulation window is available within the Utility program in addition to the emulators that run from the DOS prompt.

To access this window, choose the "Miscellaneous" menu item from the main program screen. Users can select either a simple, "dumb" terminal mode, or the "Rx/Tx" facility, which provides both Request-to-Send (RTS) and Clear-to-Send (CTS) capability.

NOTE

Make sure that optional Manual Mode switches (if used) are initially open and that they are open whenever inputting commands from the host.

Commands. The Calibration of the CAM requires the execution of some of the CAM's direct commands. In the interest of expediency, the commands are not explained here. Enter the commands precisely as instructed.

Refer to the Operation Section of this manual, or to the CAM/DCM/SCM Command Reference Guide for more information on command format and the CAM command/response protocol.

User Input Scaling. All output levels used as part of the commands from host to the CAM must be entered in millivolts or milliamps, according to the factory configuration of the unit being checked/operated.

Numerical values representing voltage levels are expressed in millivolts:

\$1AO+10012.00↵

for example, which is the command used to set CAM output to 10.012 V.

The command to set CAM output to 15.25 mA would be entered in this fashion:

\$1AO+00015.25↵

Refer to the CAM/DCM/SCM Command Reference Guide and to tables 6 and 7 of this manual for more complete information on operating the CAM using direct ASCII commands.

Trimming the Output of Voltage CAM's. Trimming unit output is a procedure in which the output level designated by the user is compared to actual unit output as measured by a connected meter. Additional commands are then entered to bring commanded output to within rated tolerances.

1. Enter AO command to set CAM output to rated zero:

\$ 1 AO s nnnnn.nn ↵

Where:

- \$** = CAM command initiator (required)
- 1** = Generic address. Applicable only when unit in setup is configured in Default Mode
- AO** = Analog Output command
- s** = sign, "+" or "--" for positive or negative
- nnnnn.nn** = the appropriate value for the rated zero of the unit being checked.

EXAMPLE:

To set a CAM whose rated output range is 0 to 10 V (or any other zero-based range) the command will be:

\$1AO+00000.00↵

CAM

For CAM's with other ranges, make sure to include the correct sign, as in the AO command for setting a -5 to $+5$ V unit:

\$1AO-05000.00

2. Note actual CAM output voltage as indicated on voltmeter in setup.
3. Trim unit zero.
 - a. Enter Write Enable (WE) command:

\$1WE

Response will be an asterisk (*).

This is the required command to allow configuration data to be written into the CAM's non-volatile memory.

- b. Enter Trim Minimum (TMN) command, incorporating actual value as observed on voltmeter:

\$1TMNsnnnnn.nn

Response will again be an asterisk (*), indicating that the CAM has accepted trim.

EXAMPLES:

After setting output to rated zero with the AO command (step 1), the connected voltmeter reads -11.12 V. To trim unit zero, the command sequence entered is:

\$1WE

Response: *

\$1TMN-11120.00

Response: *

To trim a zero reading of 9.87 V, enter:

\$1WE

Response: *

then:

\$1TMN+09870.00

Response: *

4. Repeat steps 2 and 3 until actual output voltage is within unit's rated accuracy tolerance as stated in Specifications listed in table 1.
5. Enter AO command to set CAM output to rated full-scale.
6. Note actual output voltage as indicated on voltmeter in setup.
7. Trim unit full-scale.
 - a. Enter Write Enable:

\$1WE

Response: *

- b. Enter Trim Maximum (TMX) command, incorporating actual value observed on meter:

\$1TMXsnnnnn.nn

Response will again be an *, indicating that the CAM has accepted trim.

8. Repeat steps 6 and 7 until actual output voltage is within unit's rated accuracy tolerance as stated in Specifications listed in table 1.
9. Verify correct unit trim by changing unit output (with appropriate AO command) to several random values in rated range, and noting voltmeter reading at each output level setting.

With zero and full-scale properly trimmed, CAM will provide output with specified accuracy at all levels within rated unit range.

Trimming the Output of Current CAM's. Follow the same procedure used to calibrate voltage CAM's, substituting the appropriate milliamp values for the references to voltage in steps 1 through 9.

NOTE

Current CAM's are unipolar. They do not sink current.

Unacceptable errors in unit accuracy will result if a numerical zero is used to set the unit zero. Use a nominal positive value, such as 0.5 mA:

\$1AO+00000.50

If error message is returned, or if unit fails to respond:

- Check all connections in setup
- Make sure that DEFAULT terminal of CAM is connected to ground
- Make sure "dumb" terminal emulation and RS-232C/485 configuration is compatible with unit under test.

If problems persist, contact your local Customer Service Center (numbers listed inside front cover of this manual).

Verifying CAM Basic Function

This section consists of the instructions for verifying the basic function of the standard and PRG-equipped CAM. It is divided into procedures for checking the unit's ramping rate under both host and manual (local) control, making sure that the checksum and the Acknowledge command (ACK) functions are working, and testing the standard CAM's Read Analog Output (RAO) and the PRG CAM's Read Analog Data (RAD) commands.

NOTE

There are several ways to take advantage of the CAM's discrete input terminals. This check of the basic unit function is not intended to serve as a guide for implementing the unit's capability for discrete input/output (IO) or Manual Mode operation in your application.

Refer to the Operation Section of this manual for instruction in configuring the CAM to provide:

- Up/Down Manual Control of Analog Output
- Controller Input Override
- Normally Open (NO) or Normally Closed (NC) Switch Limiting

Ramping Rate & Host Control Check. Use the same setup as was called out in the procedure for Trimming Current or Voltage CAM output. A stopwatch or similar timing device is also required.

1. Set CAM output to rated zero using the AO command.
2. **Without pressing ENTER**, type the AO command that will set CAM output to rated full-scale.
3. Start stopwatch and press ENTER simultaneously.

NOTE

*Make sure to press ENTER and start the stopwatch **simultaneously**.*

4. Monitor readout of meter used in setup.

A properly functioning, standard CAM will ramp from rated zero to full-scale (and incidentally, from rated full-scale to zero) in five seconds.

NOTE

The PRG CAM has a user-configurable ramping rate controlled with the Manual Slope (MS) command. Refer to the Operation Section of this manual, or to the explanation of the MS command in the CAM/DCM/SCM Command Reference Guide.

5. Repeat procedure in steps 1 through 4, starting this time with unit's rated full-scale output, and ramping downward to rated zero.

Ramping Rate & Manual Mode Check. CAM discrete input terminals are negative true. Open switches propagate a logic 1. The external switches used in this procedure must be open initially and whenever commands from the connected host are to be input to the CAM.

NOTE

Manual Mode input to the CAM overrides host input. Trim CAM output before checking its Manual Mode.

CAM

1. Use AO command to set unit to maximum rated output. Refer to step 1 of Trimming Voltage CAM Output procedure, earlier in this section.
2. Press and hold (close) DN push button (switch).
3. Verify that CAM output as measured on setup voltmeter ramps downward (to LO Limit Value)
4. Release DN. Press and hold (close) UP push button (switch).
5. Verify that CAM output as measured on setup voltmeter ramps upward (to HI Limit Value).
6. Release UP, and again press and hold (close) DN.
7. While CAM output is ramping downward, press and hold UP.
8. Verify that downward slew of CAM output stops and holds as long as UP is pressed, and that it begins anew when UP is released.
9. Ramp output upward, and verify that slew stops and holds as long as DN is pressed.
10. In either an upward or downward ramp, release (open) both buttons (switches).
11. Verify that output slew stops and holds.

Override of Host Control. Start with the same setup as was called out in the procedure for trimming CAM output.

1. Execute AO command to set unit output to either maximum or minimum.
2. Observe voltmeter used in setup, and during 5 second ramping window, press appropriate push button to send ramp in opposite direction.

That is, if ramping downward, press UP push button. If ramping upward, press DN.
3. Verify that voltmeter indicates reversal of ramping direction when either push button is pressed.
4. Press manual control push button (either UP or DN) to begin ramping.

5. Observe voltmeter, and during ramping, execute an AO command.
6. Verify that connected CAM returns a "MANUAL MODE ERROR" message.

Acknowledge/Checksum Check. Use the same setup described in the procedure for trimming CAM output, previously (Manual Mode switches are not required).

The Acknowledge (ACK) command is a "handshaking" routine used to verify the data sent to a connected CAM. It is implemented by means of a simple hexadecimal (hex) checksum comparison.

1. Choose an arbitrary output level from rated range of CAM under test.

NOTE

Choose a value different from the one currently being used in the CAM under test. That is, if the CAM is currently set for 4 V output, choose some value other than 4 V.

2. Enter value to CAM in setup, using Long Form of appropriately formatted AO command. Start the command with the "number" character (#) instead of and asterisk (*).

EXAMPLES:

The long form of the AO command that sets a current output CAM to 12 mA is:

1 AO + 00012.00.L

Where:

- # = Long form identifier (checksum)
- 1 = Generic unit address, used in Default Mode only
- AO = Analog Output command
- +00012.00 = Desired mA output level

The long form of the AO command that sets a 1-5 V output CAM to 3 V is:

```
#1AO+03000.00.]
```

NOTE

The Long Form of the CAM command must be used to check its ACK function.

3. Verify that values entered in step 2 match those returned by the unit in response, and that returned checksum is valid.

To calculate/verify Checksum:

- a. Determine ASCII value for each character in CAM response. Refer to keyboard/ASCII/Hex conversion table in CAM/DCM/SCM Command Reference Guide.
 - b. Calculate sum of ASCII values and determine hex equivalent of that value.
 - c. Verify that the two lowest order (right-most) digits in the hex value match those returned by the CAM in response to the command entered in step 2 of this procedure.
4. Note reading of voltmeter in setup. Changing CAM output, when long form commands are used, requires an additional command, ACK, for execution.

5. Enter short form of ACK command:

```
$1ACK.]
```

Module responds with an asterisk "*" and voltmeter indicates appropriate change in output.

CAM Configuration – Running the Utility Program

To configure the initial operating parameters of the CAM, use the same setup as was called out in the procedures of the Bench Check, earlier in this manual (Trimming Output).

Modifications to CAM operational settings are saved in the unit's electrically-erasable, programmable memory (EEPROM). The EEPROM data can be edited by the user with the Setup command, or by loading and running the Utility program on a PC.

All data stored in EEPROM is immune to any power loss in the CAM, and unless making changes from within Utility, is protected by the unit's Write Enable command.

NOTE

The Utility program is not required to set up the CAM. The unit also recognizes commands directly from the host.

Required Device Drivers. If the host being used in your system is running under version 4.0 or later of DOS or MS-DOS, a modification to the CONFIG.SYS file must be made to accommodate the Utility program.

Use an ASCII editor, such as DOS's EDLIN, or the EDIT command in the DOS 5.0 shell to install/modify the device driver for ANSI.SYS as follows:

```
DEVICE = ANSI.SYS /K
```

NOTE

The system must be rebooted in order to have the changes to CONFIG.SYS take effect.

Loading Utility. To run the program, enter:

```
utility.bat.]
```

from the appropriate DOS prompt.

NOTE

It is strongly recommended that distribution diskettes be backed up prior to use. Use the backups as working diskettes, and store the original diskettes as archives.

CAM

Utility Utilities. To generate a printed copy of the Quick Start Manual, which “walks the user through” diskette backup, and program installation and start up, make sure that a printer is connected to the parallel port of the PC being used, insert the Utility distribution diskette into the floppy drive, switch to the appropriate DOS prompt, and type:

COPY MANUAL PRN.

The best way to browse the manual file on-line is to load it into any ASCII text editor (not supplied). If desired, users can also browse the contents of the MANUAL file in DOS.

Insert the Utility disk into the floppy drive, enable the appropriate DOS prompt, and type:

TYPE [drive letter]: MANUAL | MORE.

The symbol “|” above represents the boolean OR. Do not confuse this with a lower case “L”.

The text of the manual will appear on the screen, filling a “screen page” at a time. Pressing any key scrolls to the next screen page. The <CNTRL>-C (BREAK) key combination terminates the browse. The DOS TYPE command does not have the capability to browse backward through previously viewed texts.

Once Utility is running, move the highlight selector around in the program with a mouse, or with the cursor control keys of the PC being used.

Context-Sensitive HELP. The Utility program features a system of context-sensitive helps designed to lessen the need for reference to any printed manual.

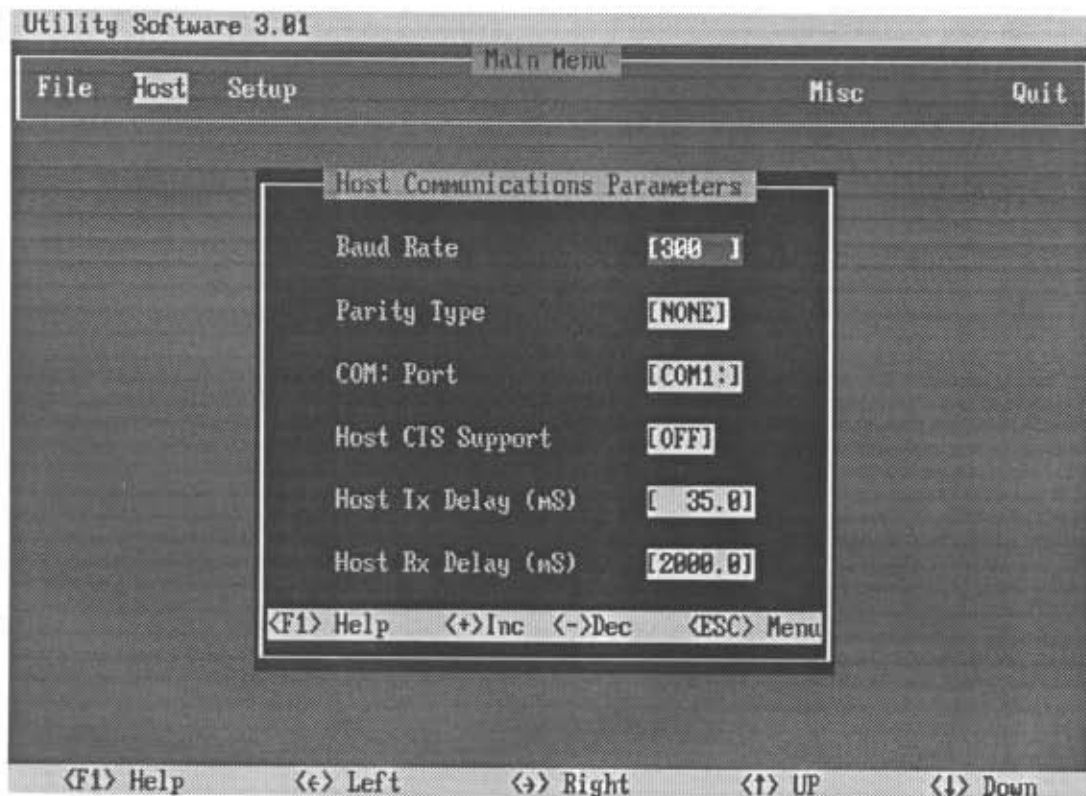

Figure 6. Utility Program Host Pull-down Menu

To access the help system, press <F1> at any time. Figure 7 shows the help screen that pops up when <F1> is pressed while the highlight selector is over the Baud Rate field of the Host Communications Parameters screen.

An informal index of all help topics can be accessed by pressing <F1> again, i.e. from any help screen, or by pressing <F1> twice from any program screen.

To leave the help system, press ESCAPE <Esc>.

1. Move highlight selector to "Host" menu item and double-click or press ENTER.

Figure 6 shows the access screen, where data on the host device is entered.

2. Data can be entered directly (a BEEP will be produced when trying to enter "illegal" values), or the space bar or the + and - keys may be used to scroll through the available values.

Fill out the parameters screen as appropriate for the type of host being used, then press ESCAPE. This returns the program to the main screen.

NOTE

Host configuration data is stored in host memory ONLY. When the Utility program is ended, the settings are lost and must be re-entered every time the program is started again.

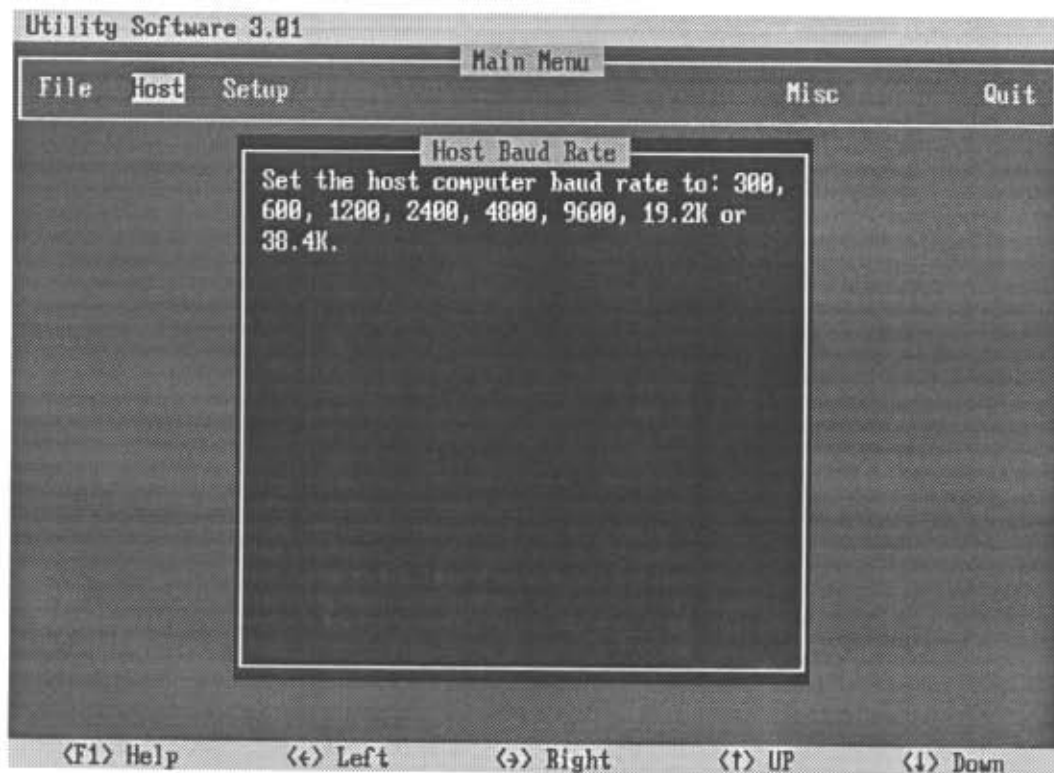

Figure 7. Utility Program Context-Sensitive Help Screen Example

CAM

3. Access the "Setup" menu next.

Move the highlight selector to the Setup menu item and double-click or press ENTER.

This will bring up the Setup Initial Access screen, shown in figure 8. The screen consists of fields for entering the connected CAM's address and its model number designator.

In Default configuration (CAM DEFAULT terminal shorted to GND), unit reads any "legal" ASCII address ("1" comes up on the screen automatically).

The "Model Number" field of the screen refers to one of the CAM model number codes listed in table 4.

4. When parameters are correct, press ENTER.

The program then checks the entered data against the settings for the connected unit. If an error code or time out is returned, refer to the Troubleshooting Section of this manual.

It is recommended that the configuration process be conducted with the connected CAM in its Default Mode, as shown in the calibration setup figures.

5. The CAM setup screen is shown in figure 9.

6. Enter data as required for the connected CAM. Refer to the help for any given field by selecting the field with the highlight and pressing <F1>.

7. When the data is correct, press <F10> to initiate a module reset.

Any changes made in the unit communications or operating parameters are not downloaded to the EEPROM until the unit receives a Module Reset (MR) command, either manually (from the terminal) or when the Setup menu is properly exited (<F10> Send Setup), and the Default Mode is de-activated.

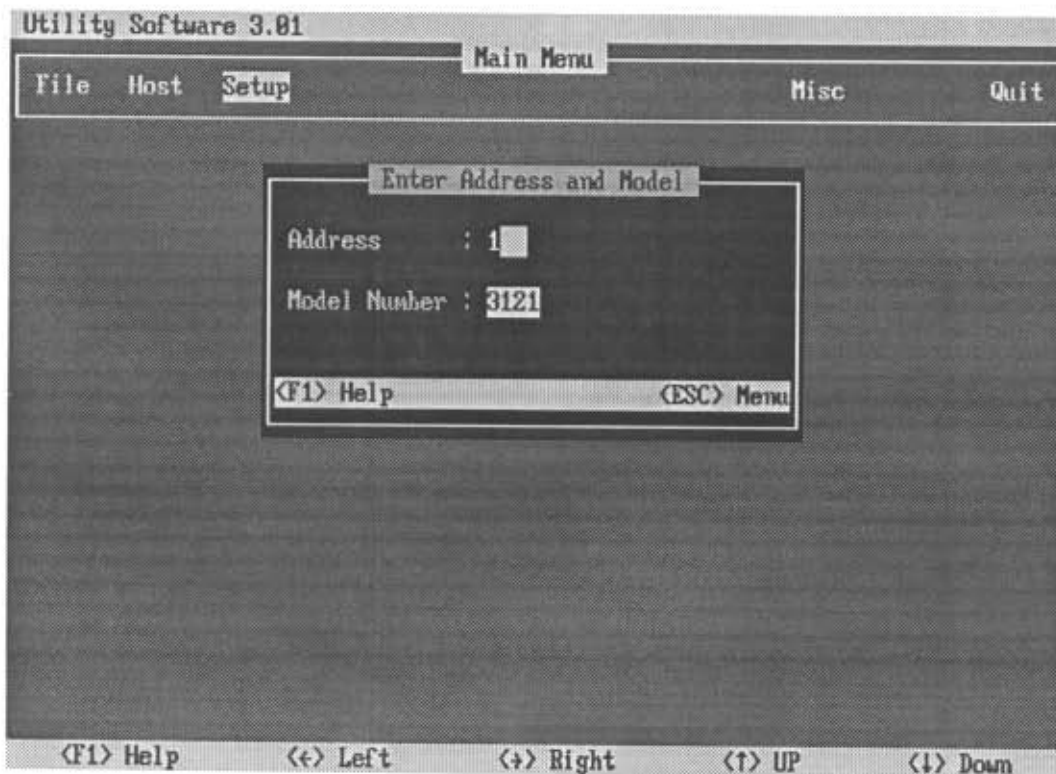

Figure 8. Utility Program Setup Menu Initial Access Pull-down

Table 4. CAM Model Designator Codes

"INPUT" Field in CAM Model Number	"OUTPUT" Field in CAM Model Number	CAM Designator Code, Standard	CAM Designator Code, PRG-equipped
RS-232C	-1 to 1 V	3121	4121
	-5 to 5 V	3131	4131
	-10 to 10 V	3141	4141
	0 to 1 V	3161	4161
	0 to 5 V	3171	4171
	0 to 10 V	3181	4181
	0 to 20 mA	3251	4251
RS-485	-1 to 1 V	3122	4122
	-5 to 5 V	3132	4132
	-10 to 10 V	3142	4142
	0 to 1 V	3162	4162
	0 to 5 V	3172	4172
	0 to 10 V	3182	4182
	0 to 20 mA	3252	4252

NOTE

The new module settings are over-ridden any time the CAM is placed in its Default Mode configuration, i.e. its DEFAULT terminal is shorted to GND.

- After reset is complete, disconnect CAM and connect next unit to be configured. If unit type is the same, it is not necessary to exit the Setup menu screen. If a different model type is to be configured, press ESCAPE to return to the main screen, and repeat this procedure from the beginning.

Installation

In this manual, the procedure for CAM installation is presented in two phases. It is recommended that the unit be physically mounted in its intended application before electrical and communications wiring.

Mounting

Mount the CAM in an area that is relatively free of dust, excessive moisture, and corrosives. Use figure 10, which gives the outline dimensions of the DIN-style unit, and figure 11, which shows the HP-style CAM.

CAM

Utility Software 3.01		LO Limit : +00000.00	
Setup : 31070000		HI Limit : +00000.00	
EDIT 3121 SETUP			
ASCII Address		[1]	[049] Decimal
Linefeeds	[OFF]	Displayed Digits	[4]
Parity Type	[NONE]	Manual Mode	[ON]
Baud Rate	[300]	Manual Mode type	[UP/DOWN]
Continuous Input	[OFF]	I.D. Register	
Limits	[ON]		
HI Limit Value	[0.00]		
LO Limit Value	[0.00]		
Echo	[OFF]		
Byte Time Delays	[0]		
<F1> Help <+> Increment <-> Decrement <F10> Send Setup <ESC> Menu			

Figure 9. Utility Program Setup Main Menu

To mount the unit on a Top-hat DIN rail, set the top lip on the back panel over the top edge of the rail (under the top edge of the rail for GR option-equipped units). Press downward, pivoting on the unit lip, until it snaps into place.

If mounting the HP-style unit in an explosionproof enclosure, note that it is not necessary to drill or tap any holes.

Squeeze the unit's spring clips inward, toward the center while placing it inside. Once in place, release the clips. They will hold it securely.

Refer to the Moore Industries catalog for mounting information on the available explosionproof enclosures that are compatible with the HP-style CAM.

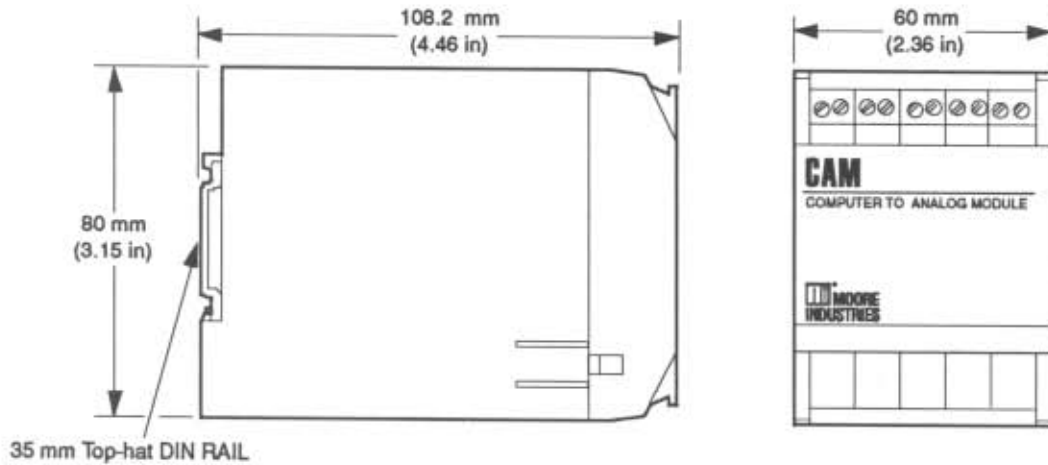

- NOTES:**
1. Add 16.76 mm (0.66 in) to length dimension when unit is equipped with GR Option.
 2. When stack mounting units, allow 31 mm (1.25 in) minimum between each module for removal.

Figure 10. DIN-style CAM Outline Dimensions

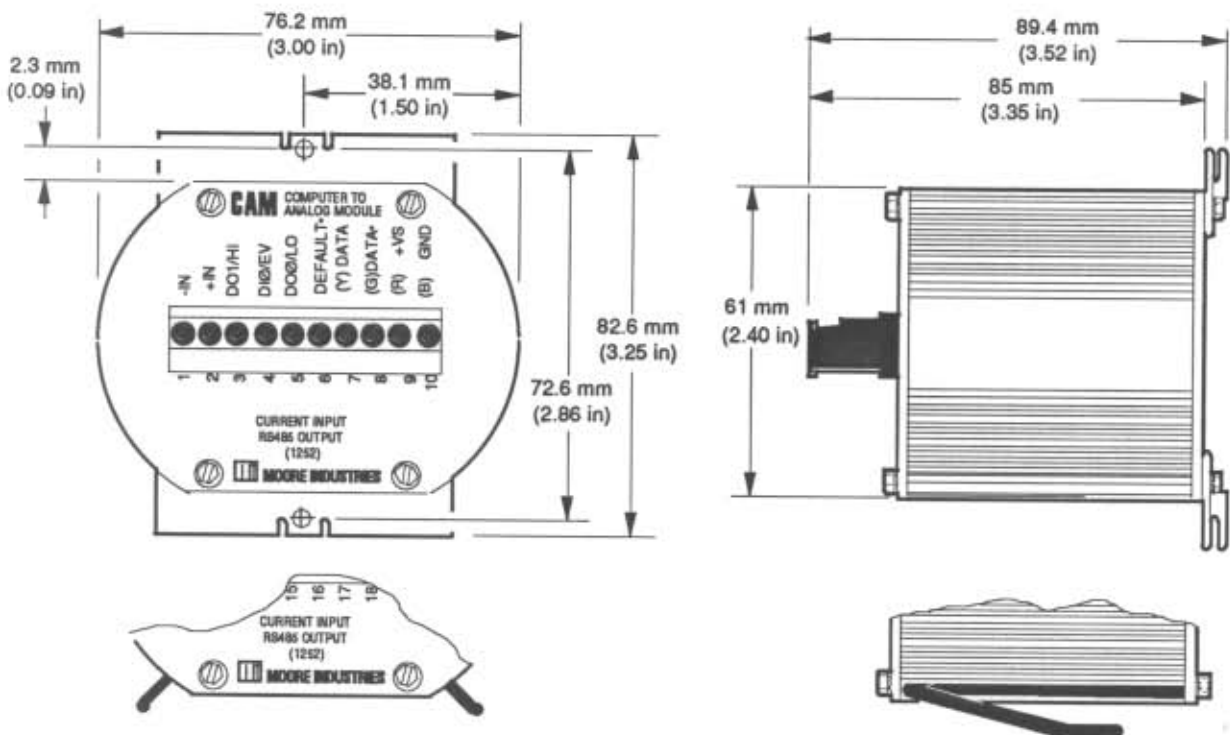

Figure 11. HP-Style CAM Outline Dimensions

CAM

Electrical Connections & Communications Wiring

There are 10 labeled terminals on the front panel of the CAM. Table 3, in the Calibration Section of this manual, lists the label abbreviations used.

Use a slotted-tip screwdriver with a head width of 0.125 in to connect wiring to the CAM terminals.

Figure 12 shows the connection of multiple RS-232C CAM's in a typical application. Note that echo must be ON in a daisy chain installation.

Figure 13 shows a typical RS-485 multi-drop hookup. Echo must be set to OFF in multiple RS-485 CAM applications.

NOTE

The use of twisted pair, shielded wiring is recommended for all low-level signal connections. Ground the shielding wire as close to the unit as is possible, or to reliable earth ground if available.

RS-232C Considerations. There are several environmental conditions that impact the use of RS-232C communications in CAM applications, particularly where multiple units are strung in series, or daisy chained.

- **Interdependency** - In a daisy chain, all CAM's are dependent on each other to echo commands and data down the line. That is, echo must be set to ON. The loss of any unit in the chain effectively disables the entire system.

Refer to the Setup window of the Utility program for information on setting echo on or off, or refer to the explanation of the Setup command in the CAM/DCM/SCM Command Reference Guide.

- **Distance** - The hard-wired distance between host and CAM in a single unit application, or the distance separating host and CAM and any daisy-chained CAM is limited to 200 feet.

Consult the factory or your local Moore Industries Sales Representative for information on compatible modems and repeaters which increase the practical distance between module and host.

- **Baud Rate** - All CAM's connected in a daisy chain must be set to operate at the same baud rate. If the rate for any unit in the application is unknown or is inadvertently changed, all units in the daisy chain will fail to communicate.

If a problem of this nature occurs, the offending unit should be reconfigured using the Default Mode (DEFAULT to GND). Default Mode affords access to unit operating parameters by effecting a universal address, 300 baud, no echo, and no parity.

- **Node Limits** - The number of CAM's that can be hooked into a single daisy chain is limited to 10 units. Consult the factory or your local Moore Industries Sales Representative for information on compatible modems and repeaters.
- **Host Operation** - The host used in a multiple unit, RS-232C scenario should be capable of full duplex, or otherwise capable of in some way handling the echoed data from each CAM in the chain.
- **Delay** - During the time that a CAM in a daisy chain is echoing all of the characters in a received command and calculating a response, additional incoming commands are written to the unit's internal buffer.

This buffer is cleared after the current command is echoed/processed.

This technique creates a time delay in propagating command and data characters through the loop. The delay is equal to the time necessary to transmit one character using the baud rate configured in the module.

Refer to table 5, which lists the standard delays. Add one unit of delay for each CAM connected in the application loop.

RS-485 Considerations. RS-485 communications incorporate a half-duplex scheme, capable of high data transfer rates over greater hard-wired distances than systems using RS-232C. There are, however, trade-offs that should be considered during installation, particularly where multiple units are connected in a multi-drop scenario.

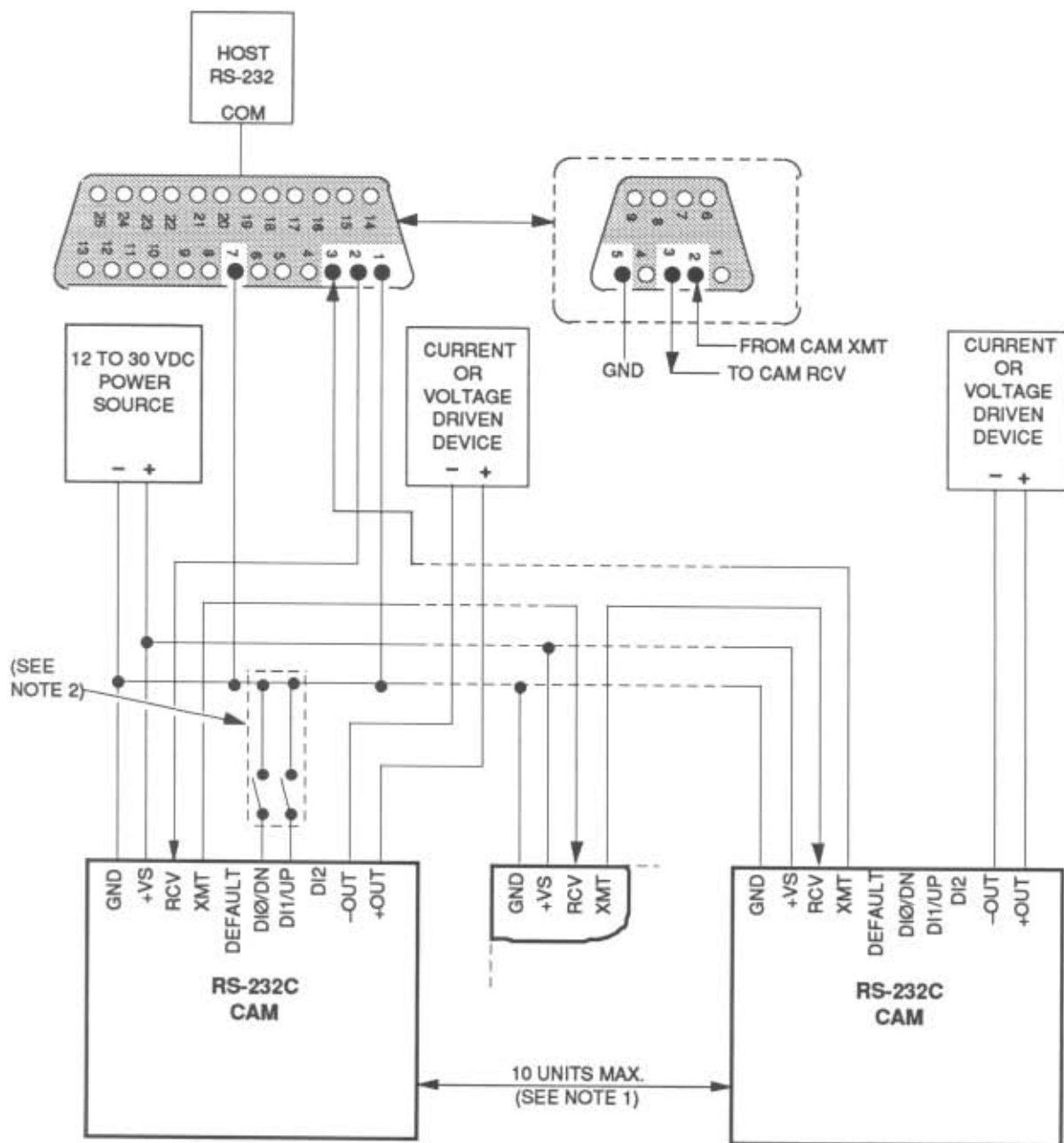

- NOTES:**
1. Consult factory for information on repeaters that allow for larger number of unit hookups.
 2. Optional, user-supplied switches for Manual Mode (local control) operation.
 3. Echo must be set to ON in all RS-232C multi-unit applications.

Figure 12. Typical Daisy Chain Serial CAM Installation (RS-232C)

CAM

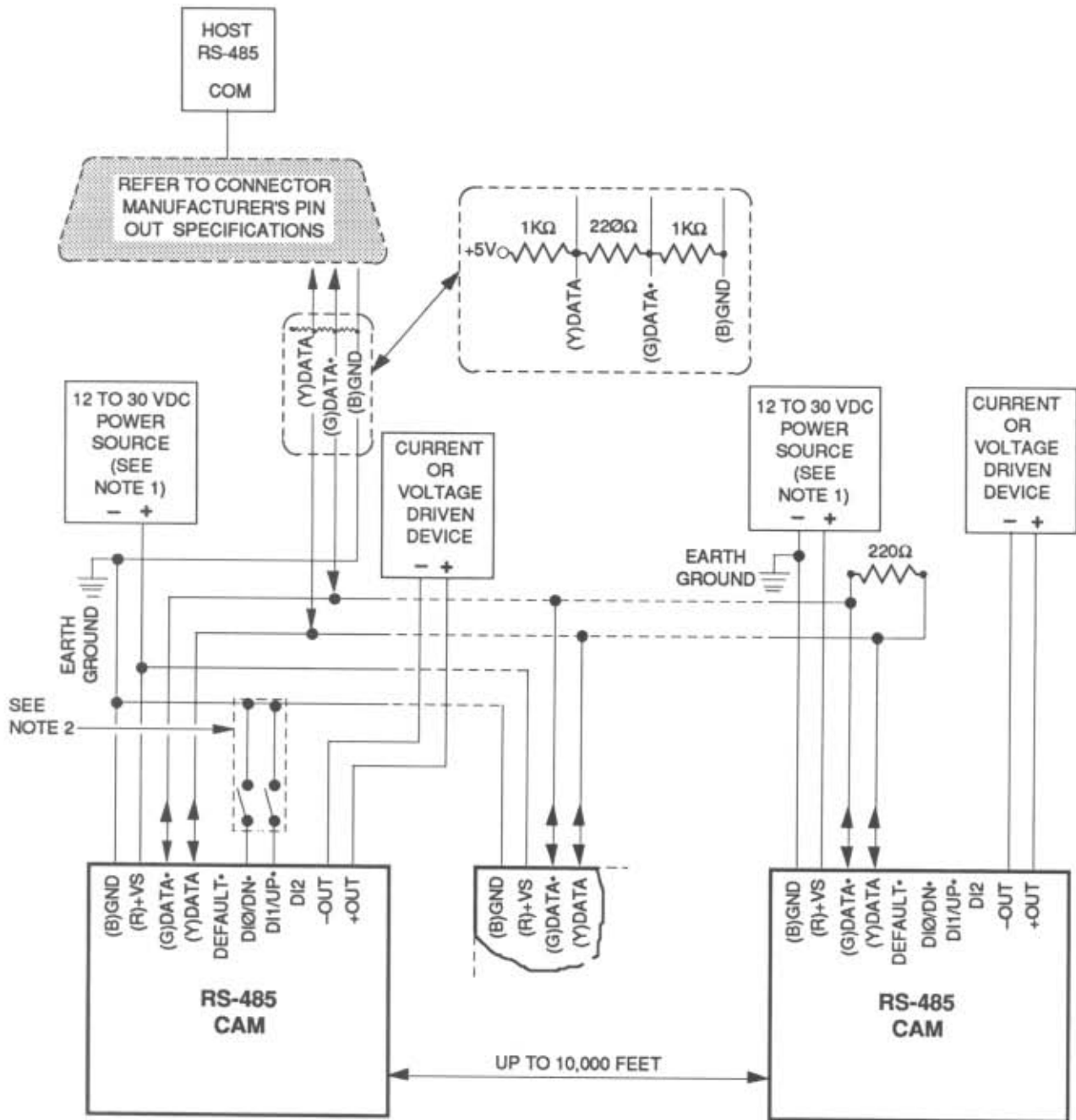

- NOTES:**
1. Up to 32 CAM's may be connected in an RS-485 scheme. Up to 124 with repeaters. Some applications may require additional power supplies. Consult factory for information on additional equipment.
 2. Optional, user-supplied switches for Manual Mode (local control) operation.
 3. Echo must be set to OFF in all RS-485 multi-drop applications.

Figure 13. Typical Multi-drop Parallel CAM Installation (RS-485)

Table 5. Command Timing

Baud Rate	Transmit Delay
300	33.3 msec
600	16.7 msec
1200	8.33 msec
2400	4.17 msec
4800	2.08 msec
9600	1.04 msec
19200	520 μ sec
38400	260 μ sec

- **Pin-Outs** - As of the date of this manual's printing, there is no industry standard for RS-485 connections. Consult the documentation for the interface board or cabling used for instruction in hooking up the CAM terminals to the proper host connector pins.
- **Interdependency** - Since RS-485 incorporates a balanced, differential wiring pair that switches between receive and transmit functions, all units must have echo set to **OFF** to avoid communications collisions.
- **Node Limits** - The number of CAM's that can be hooked into a single multi-drop is limited to 32 units. Consult the factory or your local Moore Industries Sales Representative for information on compatible modems and repeaters.
- **Noise/Reflections** - Arrange the wiring scheme in a linear fashion, with communication lines going from one CAM to the next. Avoid tree-type schemes, with one CAM functioning as a "node" to which other CAM's transmit.

Data lines should be terminated at each end with 220 Ω resistors, and should be protected with a

network of bias resistors as shown in the detail of figure 13.

Use shielded, twisted pair wiring for data lines, particularly where distances between modules exceed 1000 feet. Use parity, checksums, and the Acknowledge command to ensure error-free communications.

- **Voltage Drops** - System ground is used both as a power connection and the common reference for the CAM's transmission line receivers. Voltage drops in the GND leads may appear as common-mode voltage. It is recommended that common-mode voltages be limited to -5 V.
- **Delay** - All RS-485 CAM's are factory-configured to provide two units of delay after the receipt of a valid command. The actual delay period is baud rate-dependent (see table 5).
- **Node Limits** - The number of CAM's that can be hooked into a single multi-drop is limited to 32 units. Consult the factory or your local Moore Industries Sales Representative for information on compatible modems and repeaters.

NOTE

If the host being used transmits a carriage-return/line-feed as a single character, the delay may be set to zero to improve response time.

Refer to the Help in the Setup window of the Utility program, or to the explanation of the Setup command in the CAM/DCM/SCM Command Reference Guide for more information.

Continuous Mode Considerations

Figure 14 shows the CAM employed in conjunction with its sister module, the SCM, in examples of Continuous Mode applications. Note that to effect this or similar installations, the CAM must be equipped with the PRG Option, and the SCM must be equipped with the C Option.

CAM

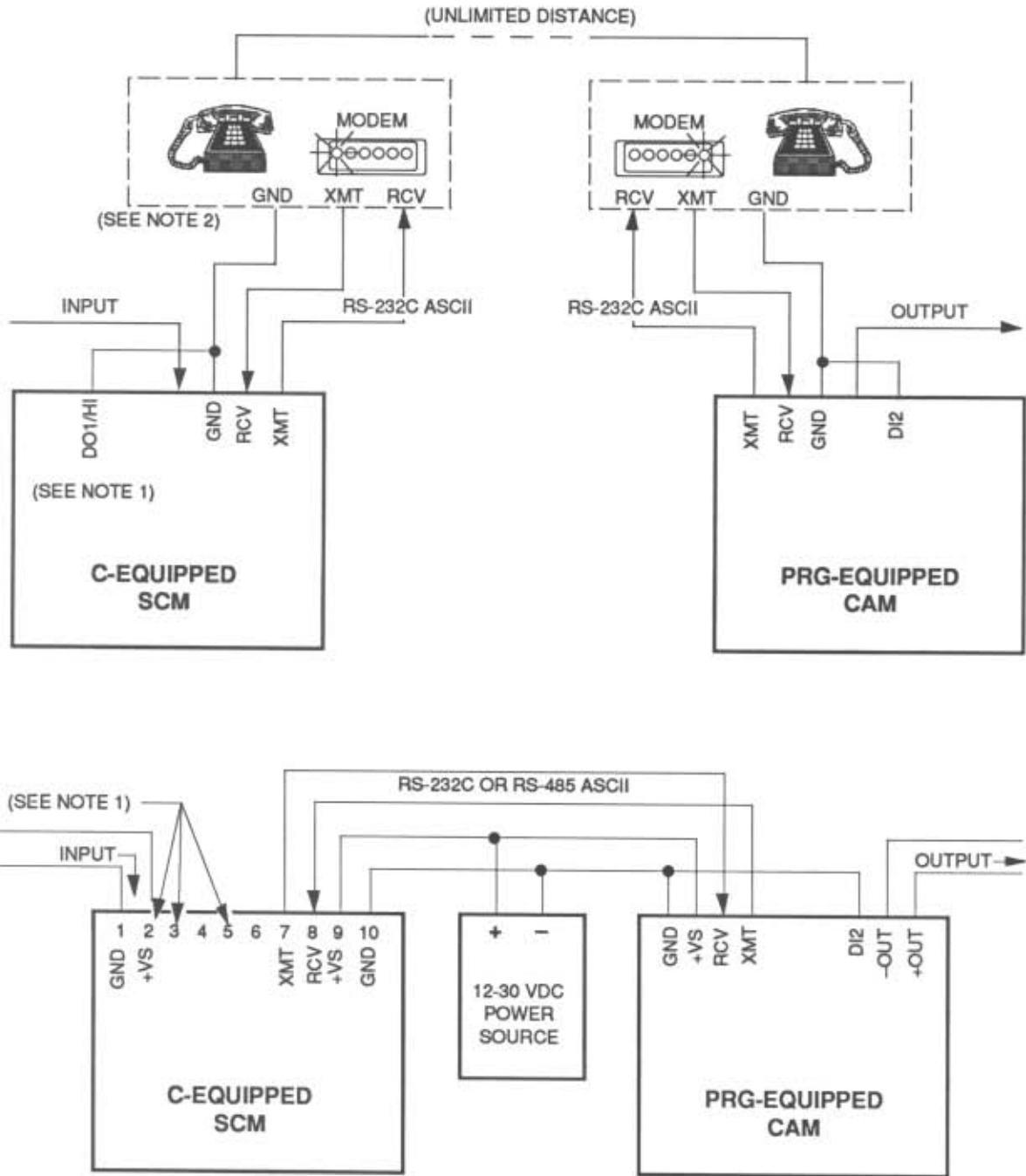

- NOTES: 1. Represents Continuous Mode Enable Terminal. Refer to SCM User's Manual or CAM, DCM, and SCM Command Reference Guide for more information.
 2. C-equipped SCM's require that the RTS signal of modems be disabled.

Figure 14. Typical SCM-to-CAM Installation

Enable/Disable. In addition to the required option, the PRG CAM shown in the bottom portion of figure 14 must have its Continuous Mode enabled.

To accomplish this, first access the Setup window in Utility (refer to the Calibration Section, earlier in this manual, for instruction on starting and running Utility). The Setup window has a selection for enabling Continuous Mode. Set this to on, and initiate a module reset (RR command) by "backing out" of the Setup window.

If desired, bypass Utility by enabling Continuous Mode "directly" in Byte #3 of the Setup command (refer to the explanation of the Setup command in the CAM/DCM/SCM Command Reference Guide).

Once Continuous Mode has been enabled, ground the DI2 terminal.

SCM's, in addition to the C Option, must have their Continuous Mode enabling terminal connected to ground. DCM's must also have one of the four available triggers activated (timer, leading edge, change of state, or input receipt). Refer to the SCM or DCM User's Manual, or to the CAM/DCM/SCM Command Reference Guide for information on SCM and DCM Continuous Mode.

NOTE

Though CAM's in Continuous Mode continue to perform host commands as received, it is impossible for the host to receive any response from the module.

The module accepts input both in the form of host commands, and in the form of what is otherwise considered the response format (output from a Continuous Mode SCM or DCM):

***+ØØ123.45**

This is especially significant if the communications lines between sending and receiving units may be susceptible to noise or other environmental factors that would result in transmit errors.

The Continuous Mode CAM does not return any error codes in response to continuous input, and so will give no indication of a communications breakdown, should one occur.

Power Supply Considerations

All CAM's employ an on-board switching regulator to maintain good efficiency over the rated 12 to 30 V power input range. This results in an inverse relationship between current draw and line voltage.

CAM's configured for voltage output consume 1 W, maximum. Current output CAM's consume 1.3 W. To determine the power (current) requirement for a multiple CAM application, multiply the number of CAM's to be used by the rated consumption value, 1 or 1.3. Divide that product by the rated voltage of the power supply to be used.

EXAMPLE:

It is intended that a 24 V power supply be used in an application calling for 4 CAM's configured for current output.

$$4 \times 1.3 = 5.2$$

$$5.2 \div 24 = 0.2167 \text{ (approximately)}$$

This means that in order to work with the CAM's properly, the power supply used must deliver a current of at least 216.7 mA.

Operation

The CAM can be operated in any of five ways; from a terminal, from within the Scan program (provided), in Continuous Mode (PRG Option required), in Manual/Local Mode, or by third party DAC software. Basically, all of these platforms simply are a means of providing ASCII string data to the connected unit(s) and reading the responses to some commands.

Table 6 lists the CAM commands. To operate the CAM, choose a platform and execute the commands as listed.

Table 6. CAM Commands

Execute:	\$aWE Required	Command Syntax:	Response Syntax:
ACKNOWLEDGE, Communications Handshake/Verify		\$aACK	*
ANALOG-to-DIGITAL READBACK, Read (Actual Output). See NOTE 1.		\$aRAD	*snnnnn.nn
ANALOG-to-DIGITAL READBACK, Trim to Metered Maximum. See NOTE 1.	✓	\$aTRX	*
ANALOG-to-DIGITAL READBACK, Trim to Metered Minimum. See NOTE 1.	✓	\$aTRN	*
IDENTIFICATION, Read Tag		\$aRID	*n.....n
IDENTIFICATION, Set Tag	✓	\$aIDname	*
ON/OFF (Logical) STATE, Read All Discrete Terminals		\$aDI	*nnnn
OUTPUT LEVEL, Read High Limit		\$aRHI	*snnnnn.nn
OUTPUT LEVEL, Read Low Limit		\$aRLO	*snnnnn.nn
OUTPUT LEVEL, Read Status of Up/Down Ramp		\$aRD	*snnnnn.nn
OUTPUT LEVEL, Set HIGH Limit	✓	\$aHIsnnnnn.nn	*
OUTPUT LEVEL, Set LOW Limit	✓	\$aLOsnnnnn.nn	*
OUTPUT LEVEL, Trim Maximum to Actual	✓	\$aTMXsnnnnn.nn	*
OUTPUT LEVEL, Trim Minimum to Actual	✓	\$aTMNsnnnnn.nn	*

Table continued on next page.

Table 6 . CAM Commands (continued)

Execute:	\$aWE Required	Command Syntax:	Response Syntax:
OUTPUT LEVEL, Change/Adjust		\$aAOsnnnnn.nn	*
OUTPUT LEVEL, Change/Adjust using Hex		\$aHXnnnn	*
OUTPUT LEVEL, Read Last AO Command		\$aRAO	*snnnnn.nn
RESET Module	✓	\$aRR	*
SCALING, Read Full-scale Setting. See NOTE 1.		\$aRMX	*snnnnn.nn
SCALING, Read Zero Setting. See NOTE 1.		\$aRMN	*snnnnn.nn
SCALING, Set Full-scale End point. See NOTE 1.	✓	\$aMXsnnnnn.nn	*
SCALING, Set Zero End point. See NOTE 1.	✓	\$aMNsnnnnn.nn	*
SET UP Module (perform module configuration)	✓	\$aSUnnnnnnnn	*
Read SETUP (Read module configuration)		\$aRSU	*nnnnnnnn
SLOPE, Read Manual Mode Rate. See NOTE 1.		\$aRMS	*snnnnn.nn
SLOPE, Read last WSL Command. See NOTE 1.		\$aRSL	*snnnnn.nn
SLOPE, Set Host-controlled Rate. See NOTE 1.	✓	\$aSLsnnnnn.nn	*
SLOPE, Set Manual Mode Rate. See NOTE 1.	✓	\$aMSsnnnnn.nn	*
Table concluded on next page.			

Table 6 . CAM Commands (concluded)

Execute:	\$aWE Required	Command Syntax:	Response Syntax:
SLOPE , Write to EEPROM. See NOTE 1.	✓	\$aWSLsnnnnn.nn	*
SLOPE , Read Present (Last SL Command). See NOTE 1.		\$aRPS	*snnnnn.nn
STARTING VALUE , Read. See NOTE 1.		\$aRSV	*snnnnn.nn
STARTING VALUE , Set. See NOTE 1.	✓	\$aSVsnnnnn.nn	*
WATCHDOG TIMER , Read. See NOTE 1.		\$aRWT	*snnnnn.nn
WATCHDOG TIMER , Set. See NOTE 1.	✓	\$aWTsnnnnn.nn	*
WRITE ENABLE (write protection OFF)		\$aWE	*

NOTES: 1. Command **REQUIRES** PRG Option.
 2. All CAM commands must be terminated with a carriage return ("ENTER" on some keyboards).
 3. Command short form is shown. To use checksum feature, begin each command with pound sign, "#", long form. Refer to Command Reference Guide for more information on CAM Checksum feature.

Executing Commands Directly — Terminal Emulation

A terminal emulation window is available within the Utility program, under the "Miscellaneous" menu. Users can select either simple, "dumb" terminal operation, or the Rx/Tx facility, which provides both RTS and Clear to Send (CTS) support, useful with modems.

With the selected type of emulation window open, users can enter commands from table 6 to operate the CAM.

To run terminal emulation, insert the Utility distribution diskette into the floppy drive, and type:

[drive designator]:TERMINAL.EXE.␣

NOTE

TERMINAL.EXE provides an active Request to Send (RTS) signal. This is required for use with some modems.

Alternatively, the Utility program diskette contains a simple executable program, written in Turbo Pascal (source code included) that will configure any PC or clone to operate as a dumb terminal. It sets communications parameters of 300 baud, no parity, no echo, and activates the COM1: port.

Make sure that the communications parameters agree with those appropriate for the type of CAM connected. If unit address and communications parameter settings are not known, place the unit in its Default Mode (refer to the Calibration Section, presented earlier in this manual).

Communications parameters for the CAM in its Default Mode are:

- 300 baud
- No parity
- No echo
- Any Address

NOTE

Multi-unit (daisy chain or multi-drop) installations are not compatible with the CAM Default Mode. Do not use the Default Mode to operate the CAM. If experiencing problems with a CAM in a multi-unit application, remove that CAM and re-calibrate.

Running the Scanning Program — Scan.bat

Moore Industries Scanning software, also provided on one of the distribution diskettes, also provides a user-friendly environment in which most of the basic unit functions can be executed.

This scan.bat program provides:

- Auto unit startup
- Real-time display of logged data
- Real-time printer output of time-stamped data
- Real-time output of time-stamped data to disk
- Real-time printer output of alarms
- Auto-save of unit configuration
- User-set time intervals for unit calls

- User-set time intervals for log-to-printer and log-to-disk reporting
- Display/Print of existing data and unit configuration files

NOTE

It is recommended that both distribution diskettes included with the CAM be backed up prior to use. Use the backups as working diskettes, and store the original diskettes as archives.

The on-line Quick Start manual provides basic instructions for backing up diskettes under DOS.

To generate a printed copy of the Quick Start Manual, insert the distribution diskette containing the file "manual.txt" into an available PC drive, make sure a printer is properly connected, and type:

COPY MANUAL PRN.␣

To "browse" the contents of the file on-line, use DOS's TYPE command with the MORE suffix.

Running the Scan Program. To run the program, enter:

SCAN.BAT.␣

from the appropriate DOS prompt.

The menu items are self-explanatory. Follow the on-screen instructions to navigate within the program and to execute its various host/CAM configuring and CAM operating functions.

NOTE

The Scanning program is NOT required to operate the CAM. The unit also recognizes commands directly from the host.

Continuous Mode

Refer to the Continuous Mode Section of Installation, earlier in this manual for information on Continuous Mode Operations.

CAM

Manual/Local Mode

Each CAM has two discrete terminals, labeled DIØ/DN and DI1/UP, which can be used to effect the ramping of CAM output based on input from external discrete logic devices (TTL, CMOS, or Contact Closure), or simple switches.

NOTE

The rate at which CAM output ramps or slews is factory-set unless the unit is equipped with the PRG Option. Refer to the explanation of Slope in the CAM/DCM/SCM Command Reference Guide.

Figures 12 or 13 in the Installation Section of this manual show how to incorporate switches with these terminals to implement Manual/Local Mode.

In addition to the switches, one of the available Manual Mode types must be enabled, either in the Setup window of the Utility program, or directly, in one byte #4 of the Setup command. Refer to the explanation of the Setup command in the CAM/DCM/SCM Command Reference Guide (Byte #4).

Normally, the terminals are pulled up to logic 1. Voltage inputs less than 1 V are read back as logic 0. Signals greater than 3.5 V are read back as logic 1.

NOTE

The CAM internal resistors supply only 0.5 mA, and therefore, self-wiping switches, designed for low current operation, should be used. For Manual Mode operation with other types of switches, provide extra pull-up current with an external resistor tied between the switch and +V.

Up/Down Local/Manual Mode. This is the standard (factory default) configuration of the discrete terminals. Table 7 is the "truth table" for the CAM in this mode.

Controller Input Local/Manual Mode. With this type of Manual/Local Mode enabled, CAM output is affected by input from an external, discrete controller. The "truth table" for this type of Manual/Local Mode is table 8.

Table 7. Up/Down Local/Manual Mode Truth Table

Action	GND Switch	DI1/UP Switch	DIØ/DN Switch
HOLD Output at Present Point (See NOTE)	Closed	Closed	Closed
Ramp UP (See NOTE)	Closed	Closed	Open
Ramp DOWN (See NOTE)	Closed	Open	Closed
NORMAL (Manual Mode Disabled)	Closed	Open	Open
NOTE: Overrides host control. Open the GND switch to re-institute host control.			

Table 8. Controller Input Local/Manual Mode Truth Table

Action	GND Switch	DI1/UP Switch	DI0/DN Switch
Ramp UP (See NOTE)	Closed	Closed	Closed
NORMAL (Manual Mode Disabled)	Closed	Closed	Open
Ramp DOWN (See NOTE)	Closed	Open	Closed
NORMAL (Manual Mode Disabled)	Closed	Open	Open
NOTE: Overrides host control. Open the GND switch to re-institute host control.			

High/Low Limiting Local/Manual Mode. With this type of Manual/Local Mode enabled, CAM output ramping is limited according to whether Normally Open (NO) or Normally Closed (NC) configuration is in effect. Enable the configuration that matches the type switch being used. Table 9 is the "truth table".

Third Party Software

Because CAM operation is based entirely on the receipt and transmittal of "straight" ASCII commands, many third party DAC software packages are readily adaptable for use with it.

Contact your local Moore Industries Sales Representative, or call Moore Industries directly for more information.

Maintenance

CAM maintenance is limited to a periodic check of secure connections terminals, and general practices for keeping the installation relatively clean and free of moisture, corrosives, or other chemical contaminants.

There are no internal or external batteries, displays, or adjustments on the unit.

Troubleshooting

The following comprises a list of things to check if problems with the CAM occur during normal operations. If, after following the recommendations of the checklist, problems persist, please contact your local Moore Industries Sales Representative or Customer Service Center.

CAM

Table 9. High/LowLimiting Local/Manual Mode Truth Table

Switch Configuration	Action	GND Switch	DI1/UP Switch	DI0/DN Switch
NO	HOLD Output at Present Point (See NOTE)	Closed	Closed	Closed
	Abort DOWNWARD Slope (See NOTE)	Closed	Open	Closed
	Abort UPWARD Slope (See NOTE)	Closed	Closed	Open
	NORMAL (Manual Mode Disabled)	Closed	Open	Open
NC	NORMAL (Manual Mode Disabled)	Closed	Closed	Closed
	Abort UPWARD Slope (See NOTE)	Closed	Open	Closed
	Abort DOWNWARD Slope (See NOTE)	Closed	Closed	Open
	HOLD Output at Present Point (See NOTE)	Closed	Open	Open
NOTE: Overrides any command from host. Open the GND switch to re-institute host control.				

Defective units may be returned to the factory. Follow the instructions on the back cover of this manual.

PROBLEM:

A CAM in the system does not respond to Host commands.

ACTION:

- Connections.** Make sure all connections to and from the unit are secure. Refer to the figures in the Installation Section of this manual, and verify that the terminals of the CAM are connected to the appropriate sensor type or discrete input device, and that the data lines are properly connected to the communications port of the Host.

- Baud Rate.** Check that the baud rate being used by the Host is the same as that programmed in the CAM. If the setting of the CAM is unknown, connect the DEFAULT terminal to ground as shown in figures 1 through 7 in the Calibration Section, and run the Utility program (it may be necessary to remove the unit from the application to accomplish this).
- Echo.** If the installation incorporates multiple CAM's in a daisy-chain hookup, make sure that the ECHO has been turned on in all units. Refer to the Setup window of the Utility program.
- Address.** If the installation incorporates multiple CAM's in either a daisy-chain or multi-drop hookup, make sure that each unit was setup with a unique address.

5. Finally, make sure that the command being entered is correctly formatted, and that the checksum, if used, is correctly calculated. If problems persist, contact Moore Industries' Customer Service Department.

PROBLEM:

A CAM responds with an ERROR message.

ACTION:

1. **ADDRESS ERROR.** There are four ASCII values that are illegal for use as module addresses; the NULL character (00 hex), the carriage return (0D hex), the \$ character (24 hex), and the # character (23 hex). Use the Utility program to set the address of the CAM's used in the system. The program does not allow illegal addresses to be loaded into module memory.

NOTE

An attempt to use the Continuous Input Address command to specify an illegal address or an address identical to the polling address will cause an error.

2. **SYNTAX ERROR.** Command was improperly formatted. Refer to the explanation and example of the offending command in the Operation Section of this manual. Refer to Operation Section, previously, for a listing of all "legal" CAM commands and command syntax.
3. **BAD CHECKSUM.** This error message is returned when the checksum included in the command does not match the value calculated by the unit. This can result from noise or other interference on the data lines. Repeat the command, and if the error persists, re-calculate the command checksum. If problems continue, attempt the command using a lower baud rate.

4. **COMMAND ERROR.** This occurs when a command is not recognized by the CAM. Make sure that the command is correctly formatted; all upper-case (capital) letters.
5. **PARITY ERROR.** Make sure the parity of the host and all the CAM's in the system are set the same; even, odd, or none. Random parity errors are occasionally produced as a result of noise on the data lines. Attempt a re-issue of the command to correct this.
7. **VALUE ERROR.** This error results when an incorrect character is used as a numerical value. Remember, hex values range from 0 to 9 and A to F only. Refer to appendix A to check for the desired hex value and re-issue the command.
8. **WRITE PROTECTED.** The command was aborted because the CAM Write Protection was not disabled first. Execute a \$aWE0 command, and re-issue the offending command.

PROBLEM:

Continuous Mode Producing Erratic Communications, Inaccurate/Incorrect Responses.

ACTION:

In some cases, especially if a large number of Edge-Triggered modules are connected in a daisy-chain, the amount of data transmitted may overload the serial port buffer of the Host device.

To remedy this, the incoming data should be slowed down by increasing the delay programmed by the Continuous Timer parameter in the Setup window of the Utility program (\$aCT+nnnnn.nn.L, as an alternative).

Figures and Tables

Figure 1.	RS-232C Calibration Hookup, 25-Pin Connector	8
Figure 2.	RS-232C Calibration Hookup, 9-Pin Connector	8
Figure 3.	RS-485 Calibration, Non-PC Host.....	9
Figure 4.	RS-485 Hookup, RS-232C Port w/25-Pin Connector	10
Figure 5.	RS-485 Hookup, RS-232C Port w/9-Pin Connector	10
Figure 6.	Utility Program Host Pull-down Menu	16
Figure 7.	Utility Program Context-sensitive Help Example	17
Figure 8.	Utility Program Setup Menu Initial Access Pull-down	18
Figure 9.	Utility Program Setup Main Menu	20
Figure 10.	DIN-style CAM Outline Dimensions	21
Figure 11.	HP-style CAM Outline Dimensions	21
Figure 12.	Typical Daisy Chain Serial CAM Installation	23
Figure 13.	Typical Multi-drop Parallel CAM Installation	24
Figure 14.	Typical SCM-to-CAM Continuous Mode Installation	26
Table 1.	CAM Operational and Performance Specifications.....	2-3
Table 2.	CAM Calibration Equipment	6
Table 3.	CAM Terminal Labeling	7
Table 4.	CAM Model Designator Codes	19
Table 5.	CAM Command Timing Delays in Daisy Chain	25
Table 6.	CAM Commands	28-30
Table 7.	Up/Down Local/Manual Mode Truth Table	32
Table 8.	Controller Input Local/Manual Mode Truth Table	33
Table 9.	High/LowLimiting Local/Manual Mode Truth Table	34

RETURN PROCEDURES

To return equipment to Moore Industries for repair, follow these four steps:

1. Call Moore Industries and request a Returned Material Authorization (RMA) number.

Warranty Repair –

If you are unsure if your unit is still under warranty, we can use the unit's serial number to verify the warranty status for you over the phone. Be sure to include the RMA number on all documentation.

Non-Warranty Repair –

If your unit is out of warranty, be prepared to give us a Purchase Order number when you call. In most cases, we will be able to quote you the repair costs at that time. The repair price you are quoted will be a "Not To Exceed" price, which means that the actual repair costs may be less than the quote. Be sure to include the RMA number on all documentation.

2. Provide us with the following documentation:
 - a) A note listing the symptoms that indicate the unit needs repair
 - b) Complete shipping information for return of the equipment after repair
 - c) The name and phone number of the person to contact if questions arise at the factory
3. Use sufficient packing material and carefully pack the equipment in a sturdy shipping container.
4. Ship the equipment to the Moore Industries location nearest you.

The returned equipment will be inspected and tested at the factory. A Moore Industries representative will contact the person designated on your documentation if more information is needed. The repaired equipment, or its replacement, will be returned to you in accordance with the shipping instructions furnished in your documentation.

WARRANTY DISCLAIMER

THE COMPANY MAKES NO EXPRESS, IMPLIED OR STATUTORY WARRANTIES (INCLUDING ANY WARRANTY OF MERCHANTABILITY OR OF FITNESS FOR A PARTICULAR PURPOSE) WITH RESPECT TO ANY GOODS OR SERVICES SOLD BY THE COMPANY. THE COMPANY DISCLAIMS ALL WARRANTIES ARISING FROM ANY COURSE OF DEALING OR TRADE USAGE, AND ANY BUYER OF GOODS OR SERVICES FROM THE COMPANY ACKNOWLEDGES THAT THERE ARE NO WARRANTIES IMPLIED BY CUSTOM OR USAGE IN THE TRADE OF THE BUYER AND OF THE COMPANY, AND THAT ANY PRIOR DEALINGS OF THE BUYER WITH THE COMPANY DO NOT IMPLY THAT THE COMPANY WARRANTS THE GOODS OR SERVICES IN ANY WAY.

ANY BUYER OF GOODS OR SERVICES FROM THE COMPANY AGREES WITH THE COMPANY THAT THE SOLE AND EXCLUSIVE REMEDIES FOR BREACH OF ANY WARRANTY CONCERNING THE GOODS OR SERVICES SHALL BE FOR THE COMPANY, AT ITS OPTION, TO REPAIR OR REPLACE THE GOODS OR SERVICES OR REFUND THE PURCHASE PRICE. THE COMPANY SHALL IN NO EVENT BE LIABLE FOR ANY CONSEQUENTIAL OR INCIDENTAL DAMAGES EVEN IF THE COMPANY FAILS IN ANY ATTEMPT TO REMEDY DEFECTS IN THE GOODS OR SERVICES, BUT IN SUCH CASE THE BUYER SHALL BE ENTITLED TO NO MORE THAN A REFUND OF ALL MONIES PAID TO THE COMPANY BY THE BUYER FOR PURCHASE OF THE GOODS OR SERVICES.

ANY CAUSE OF ACTION FOR BREACH OF ANY WARRANTY BY THE COMPANY SHALL BE BARRED UNLESS THE COMPANY RECEIVES FROM THE BUYER A WRITTEN NOTICE OF THE ALLEGED DEFECT OR BREACH WITHIN TEN DAYS FROM THE EARLIEST DATE ON WHICH THE BUYER COULD REASONABLY HAVE DISCOVERED THE ALLEGED DEFECT OR BREACH, AND NO ACTION FOR THE BREACH OF ANY WARRANTY SHALL BE COMMENCED BY THE BUYER ANY LATER THAN TWELVE MONTHS FROM THE EARLIEST DATE ON WHICH THE BUYER COULD REASONABLY HAVE DISCOVERED THE ALLEGED DEFECT OR BREACH.

RETURN POLICY

For a period of thirty-six (36) months from the date of shipment, and under normal conditions of use and service, Moore Industries ("The Company") will at its option replace, repair or refund the purchase price for any of its manufactured products found, upon return to the Company (transportation charges prepaid and otherwise in accordance with the return procedures established by The Company), to be defective in material or workmanship. This policy extends to the original Buyer only and not to Buyer's customers or the users of Buyer's products, unless Buyer is an engineering contractor in which case the policy shall extend to Buyer's immediate customer only. This policy shall not apply if the product has been subject to alteration, misuse, accident, neglect or improper application, installation, or operation. THE COMPANY SHALL IN NO EVENT BE LIABLE FOR ANY INCIDENTAL OR CONSEQUENTIAL DAMAGES.



WORLDWIDE • www.miinet.com

United States • info@miinet.com Tel: (818) 894-7111 • FAX: (818) 891-2816	Belgium • info@mooreind.be Tel: 03/448.10.18 • FAX: 03/440.17.97	China • sales@mooreind.sh.cn Tel: 86-21-62491499 • FAX: 86-21-62490635
Australia • sales@mooreind.com.au Tel: (02) 8536-7200 • FAX: (02) 9525-7296	The Netherlands • sales@mooreind.nl Tel: (0)344-617971 • FAX: (0)344-615920	United Kingdom • sales@mooreind.com Tel: 01293 514488 • FAX: 01293 536852